

Speedway 90° Flat Elbows

Fitting Type: **FE90**

SW Δ -FE90-WIDTH-RADIUS \circ

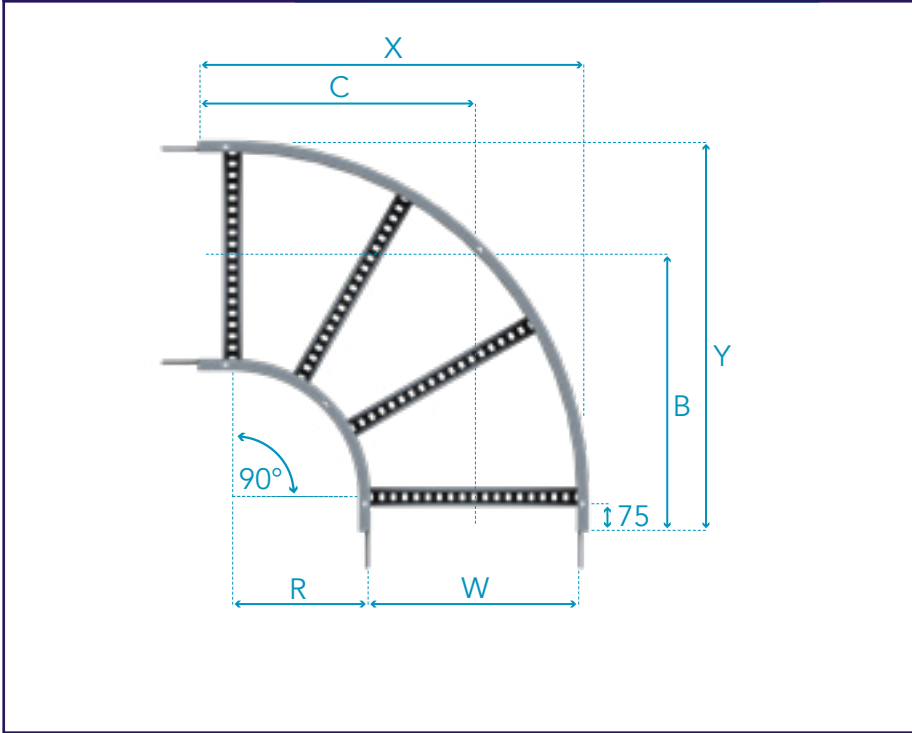

Part Number	No of Rungs	Dimensions (mm)					Weight (kg)			
		R	W	B	C	X	Y	SW4	SW5	SW6
SW Δ -FE90-150-300R- \circ	2	300	150	450	450	545	525	4.19	4.44	6.7
SW Δ -FE90-300-300R- \circ	3		300	525	525	695	675	5.23	5.51	8.23
SW Δ -FE90-450-300R- \circ	4		450	600	600	845	825	6.77	7.1	10.45
SW Δ -FE90-600-300R- \circ	4		600	675	675	995	975	7.97	8.35	12.22
SW Δ -FE90-750-300R- \circ	5		750	750	750	1145	1125	11.41	11.83	15.11
SW Δ -FE90-900-300R- \circ	5		900	825	825	1295	1275	13.06	13.53	17.11
SW Δ -FE90-150-600R- \circ	4	600	150	750	750	845	825	6.53	6.94	10.44
SW Δ -FE90-300-600R- \circ	4		300	825	825	995	975	7.73	8.19	12.21
SW Δ -FE90-450-600R- \circ	5		450	900	900	1145	1125	9.45	9.95	14.65
SW Δ -FE90-600-600R- \circ	5		600	975	975	1295	1275	10.82	11.37	16.65
SW Δ -FE90-750-600R- \circ	7		750	1050	1050	1445	1425	15.81	16.4	20.86
SW Δ -FE90-900-600R- \circ	7		900	1125	1125	1595	1575	17.9	18.53	23.29



Finishes & Materials:



Supplied with:

FIXING SETS x16

Not Required:



Δ = Select a System Type \circ = Select a Finish & Material

Weights shown are for standard hot dip galvanised finish only, for Stainless Steel and Silicon Rich Steel weight conversion factors please refer to the Engineering Data Section of our catalogue (Page 213).