

Reducer Right

Fitting Type: RR

SW△-RR-WIDTH PRIMARY-WIDTH SECONDARY-○

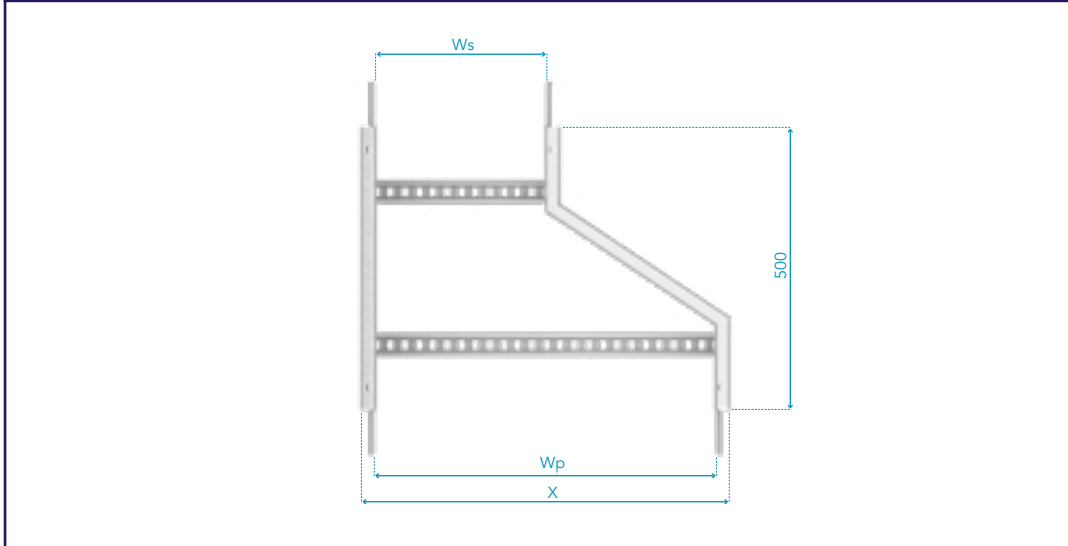

Part Number	Dimensions (mm)			Weight (kg)		
	Wp	Ws	X	SW4	SW5	SW6
SW△-RR-300-150-○	300	150	350	3.21	3.36	5.06
SW△-RR-450-150-○	450		500	3.63	3.8	5.7
SW△-RR-600-150-○	600		650	4.11	4.31	6.42
SW△-RR-750-150-○	750		800	4.93	5.14	7.16
SW△-RR-900-150-○	900		950	5.47	5.73	7.92
SW△-RR-450-300-○	450	300	500	3.54	3.69	5.51
SW△-RR-600-300-○	600		650	3.96	4.13	6.14
SW△-RR-750-300-○	750		800	4.82	5.02	6.86
SW△-RR-900-300-○	900		950	5.37	5.58	7.6
SW△-RR-600-450-○	600	450	650	3.88	4.03	5.96
SW△-RR-750-450-○	750		800	4.74	4.91	6.59
SW△-RR-900-450-○	900		950	5.27	5.47	7.31
SW△-RR-750-600-○	750	600	800	4.71	4.86	6.4
SW△-RR-900-600-○	900		950	5.18	5.35	7.03
SW△-RR-900-750-○	900	750	950	5.15	5.3	6.84

△ = Select a System Type ○ = Select a Finish & Material

Finishes & Materials:



Supplied with:

FIXING SETS x16



Weights shown are for standard hot dip galvanised finish only, for Stainless Steel and Silicon Rich Steel weight conversion factors please refer to the Engineering Data Section of our catalogue (Page 213).